

SHELL-COME HOME

by John MacPhail of Art East Quilting Co.



John MacPhail founded the Art East Quilting Co. on Cape Breton Island. A lifelong maker with a background in garment construction, John's "accidental" discovery of quilting has evolved into a global brand. He has published more than 40 original patterns across six continents. Known for his unique pictorial quilts and quirky animals, John fosters a vibrant online community, hosting international sew-alongs for thousands of makers worldwide. Often collaborating with industry leaders, such as Riley Blake Designs and FreeSpirit Fabrics, John inspires the quilting world with his modern, artful approach.

Slow and steady wins the race, but a turtle with a house on his back? That's just smart real estate! This quirky 20" x 20" block is the perfect size for a whimsical wall-hanging, tote bag or pillow. Before you dive into the deep end, here is everything you need to know to ensure your turtle stays on track.

The *Shell-come Home* block draws from John's lifelong fascination with creatures that carry their sanctuaries on their backs. This childhood curiosity found new relevance as global warming brings the leatherback sea turtle further north than ever recorded—reaching the shores of John's home. The pattern pays tribute to nature's resilience in the

face of man-made challenges, offering a heartfelt reminder that "home" is a portable state of mind. It celebrates the strength of the wanderer and the comforting truth that home is where you make it—and you can always take it with you.

Tips

Stay Organized—With many pieces in play, labeling is your best friend. John recommends using adhesive labels as you cut:

- **UPPERCASE** letters: Background fabric.
- **lowercase** letters: All other fabrics.

Accuracy is Key—All measurements are in inches and include a ¼" seam allowance. In a detailed block like this, consistency is everything. Test your seam allowance before starting to ensure your finished turtle doesn't outgrow its "shell."

Press for Success—To reduce bulk at the intersections, press all seams open. For best results, try a wool pressing mat, a wooden clapper, and a fabric treatment like the Acorn Easy Press Fabric Treatment™ on seams.

Technique

You'll see this *Stitch & Flip* technique—also known as snowballing corners—used often to create shapes beyond basic squares and rectangles:

1. Place your small piece on the corner of a larger piece, right sides together.
2. Draw a diagonal line from corner to corner and stitch directly on the line.
3. Trim the excess fabric ¼" away from the seam toward the corner.
4. Flip the fabric over and press the seam open.

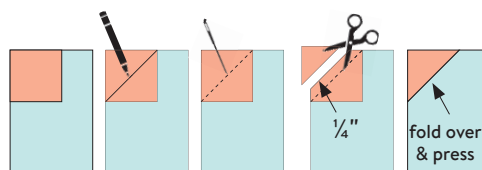

Fabric Requirements

BACKGROUND	12" x width of fabric	INNER HOUSE	4 ½" x 11"
TURTLE LIGHT	4 ½" x 22"	ROOF	4 ½" x 11"
HOUSE SIDE	4 ½" x 14"	TURTLE DARK	4 ½" x 11"
BELLY	4 ½" x 11"	EYES	1 ½" x 4 ½"
HOUSE FRONT	4 ½" x 11"		



Cutting Guide

BACKGROUND FABRIC

PIECE	QTY	SIZE
A	1	1 ¼ x 1 ¼
B	3	1 ¾ x 1 ¾
C	2	2 ½ x 2 ½
D	2	2 ¾ x 2 ¾
E	1	3 x 4 ¼
F	1	1 ¾ x 7 ¾
G	1	1 ½ x 4 ¼
H	1	1 ½ x 4 ¾
I	1	1 ½ x 5 ½

PIECE	QTY	SIZE
J	1	1 ¼ x 2
K	1	2 ½ x 6
L	1	2 ½ x 3 ½
M	2	2 x 6

PIECE	QTY	SIZE
N	1	1 ¼ x 6
O	1	3 ¾ x 7 ¼
P	2	3 x 15 ½
Q	2	3 x 20 ½

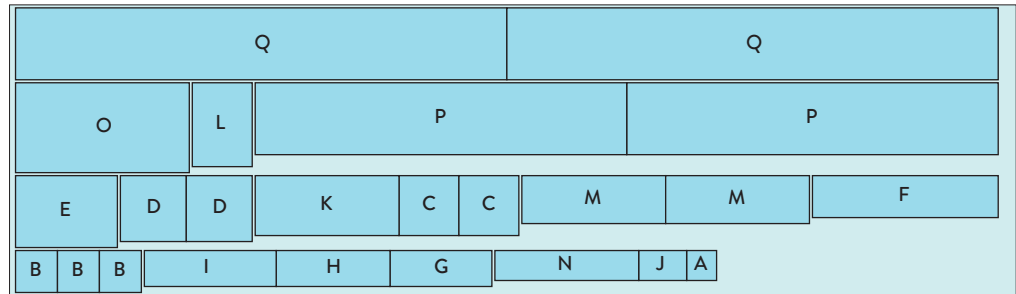

FEATURE FABRICS

PIECE	QTY	SIZE
EYES		

a	2	1 x 1 ½
---	---	---------



TURTLE LIGHT

b	1	1 ½ x 1 ½
c	1	1 x 1 ½
d	2	1 ½ x 3
e	2	1 x 1
f	1	3 x 3 ½
g	1	3 x 7 ¼
h	1	2 ½ x 4 ¼
i	1	1 ¾ x 1 ¾

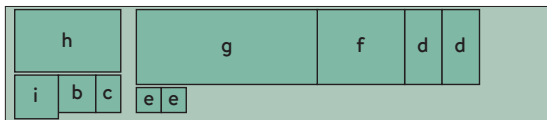

TURTLE DARK

j	1	1 x 3
k	1	1 ½ x 3 ½
l	1	1 ½ x 1 ½
m	1	2 x 5 ¼
n	1	2 x 2



BELLY

o	3	1 ½ x 1 ½
p	1	1 ¼ x 1 ¾
q	1	1 ¾ x 3 ½
r	1	1 ¾ x 2 ¾

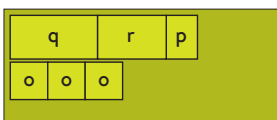

PIECE	QTY	SIZE
INNER HOUSE		

s	1	2 x 2
t	1	1 ½ x 2
u	2	1 ¾ x 3

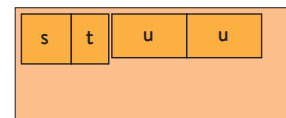

HOUSE SIDE

v	1	1 ¾ x 3
w	2	2 x 3
x	2	1 ¾ x 7 ¼

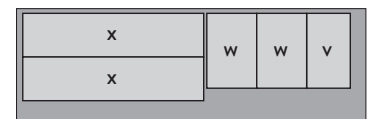

HOUSE FRONT

y	1	2 x 5
z	1	1 ½ x 2
aa	1	3 ¾ x 5

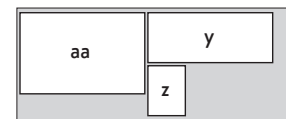

ROOF

bb	1	2 ¾ x 7 ¼
cc	1	2 ¾ x 2 ¾
dd	2	1 ½ x 1 ½



Block Assembly

Follow the Stars—keep an eye out for stars (★) in the diagrams and text. These indicate points that need to be matched to ensure the design flows perfectly.

STEP 1—UPPER TURTLE UNIT

Stitch the two **a** pieces, the **b** piece and the **c** piece in a sequence, as shown, creating the **Eyes Unit** (this unit should measure 3" x 1 1/2"). Press.

Stitch the two **d** pieces, the **Eyes Unit** and the **j** piece in a sequence, as shown, creating the **Face Unit** (3" x 4"). Press.

Stitch & flip one of the **B** pieces and the **A** piece to the top right and bottom right corners, respectively, of the **Face Unit**, as shown. Trim and press.

Stitch the **E** piece to the top of the **Face Unit**, as shown, creating the extended **Face Unit** (3" x 7 3/4"). Press and set aside.

Stitch the **t** piece to the **z** piece, as shown (3 1/2" x 1 1/2"). Press.

Stitch & flip the **s** piece to the top left corner of piece **f** and one of the **e** pieces to the top right corner of piece **k**, as shown. Trim and press.

★ Stitch the **t/z** unit, the **f/s** unit and the **k/e** unit in a sequence, as shown, matching the point where the **z** piece meets the **s** piece, as marked on the diagram with a star, creating the **Back Head Unit** (3 1/2" x 5"). Press and set aside.

Stitch & flip one of the **D** pieces and the **cc** piece to the top right and left corners, respectively, of the **aa** piece, as shown. Note that you will need to trim and press the **D** piece before stitching the **cc** piece, as they overlap. Trim and press.

Stitch the **y** piece to the left of the **Back Head Unit**, as shown (5" x 5"). Press.

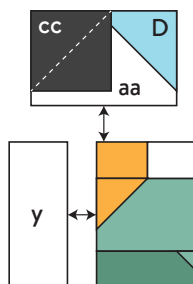
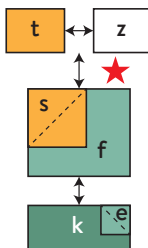
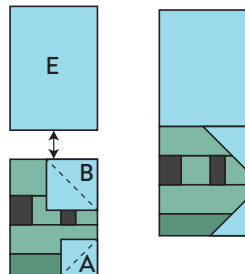
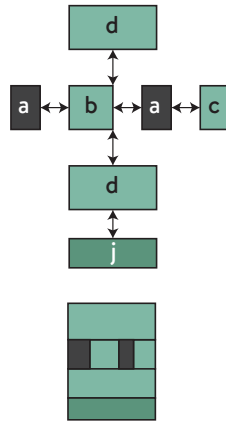

Stitch the **aa/D/cc** unit to the top of the extended **Back Head Unit**, as shown, creating the **Front House Unit** (5" x 7 3/4"). Press and set aside.

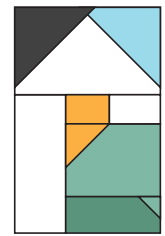

Stitch & flip the remaining **D** piece to the top left corner of the **bb** piece, as shown. Trim and press.

Stitch the two **w** pieces, the two **u** pieces and the **v** piece in a sequence, as shown, creating the **Windows Unit** (7 1/4" x 3"). Press.

Stitch the **bb/D** unit, the two **x** pieces and the **Windows Unit** in a sequence, as shown, creating the **Back House Unit** (7 1/4" x 7 3/4"). Press.

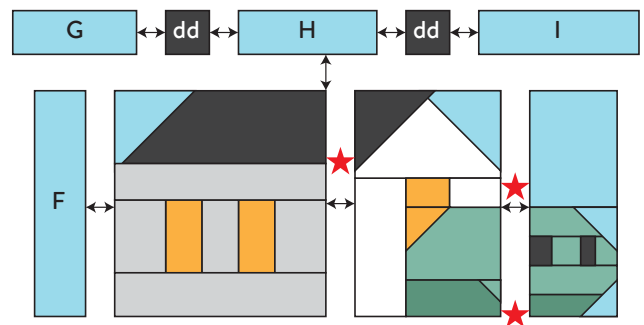
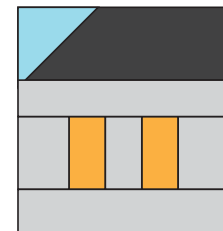
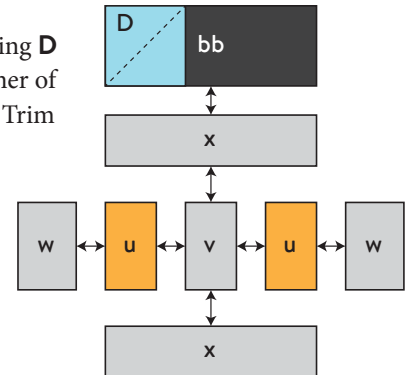

Stitch the **G** piece, the two **dd** pieces, the **H** piece and the **I** piece in a sequence, as shown, creating the **Chimneys Unit** (15 1/2" x 1 1/2"). Press.

★ Stitch the **F** piece, the **Back House Unit**, the **Front House Unit** and the extended **Face Unit** in a sequence, as shown, matching the points where the roof meets, where the top of the head meets and where mouth meets, as marked on the diagram with stars, creating the **Main House Unit** (15 1/2" x 7 3/4"). Press. >



Stitch the **Chimneys Unit** to the top of the **Main House Unit**, as shown, creating the **Upper Turtle Unit** (15 1/2" x 8 3/4"). Press and set aside.



STEP 2—LOWER TURTLE UNIT

Stitch & flip the **i** piece to one of the **B** pieces, as shown, creating a half-square triangle (HST). Trim and press.

Stitch & flip the remaining **e** piece to the bottom left corner of piece **p**, as shown. Trim and press.

Stitch the **p/e** unit to the right of the **B/i** HST, as shown, creating the **Tail Unit** (this unit should measure 2 1/2" x 1 3/4"). Press.

Stitch the **K** piece to the bottom of the **Tail Unit**, as shown (2 1/2" x 7 1/4"). Press and set aside.

Stitch & flip the **n** piece to the top right corner of one of the **M** pieces, as shown. Trim and press.

Stitch the remaining **M** piece to the right of the **M/n** unit, as shown (3 1/2" x 6"). Press.

Stitch the **q** piece to the top of the **M/M/n** unit, as shown, creating the **Back Hind Flipper Unit** (3 1/2" x 7 1/4"). Press and set aside.

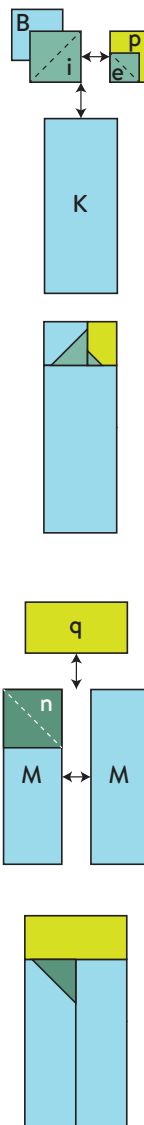

Stitch & flip the remaining **B** piece to the bottom right corner of piece **m**, as shown. Trim and press.

Stitch the **J** piece to the bottom of the **m/B** unit, as shown (2" x 6"). Press.

Stitch the **N** piece to the left of the **m/B/J** unit, as shown, creating the **Back Front Flipper Unit** (2 3/4" x 6"). Press.

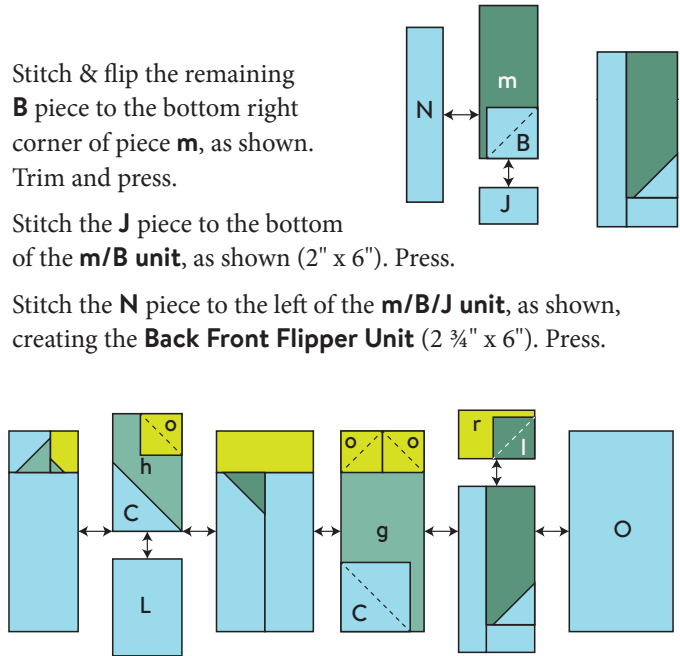

Stitch & flip one of the **C** pieces and one of the **o** pieces to diagonally opposing corners of the **h** piece, as shown. Trim and press.

Stitch the **L** piece to the bottom of the **h/C/o** unit, as shown, creating the **Front Hind Flipper Unit** (2 1/2" x 7 1/4"). Press.

Stitch & flip the remaining two **o** pieces to the top two corners of the **g** piece and the remaining **C** piece to the bottom left corner of the **g** piece, as shown. Trim and press.

Stitch & flip the **l** piece to the bottom right corner of the **r** piece, as shown. Trim and press.

Stitch the **r/l** unit to the top of the **Back Front Flipper Unit**, as shown (2 1/2" x 7 1/4"). Press.

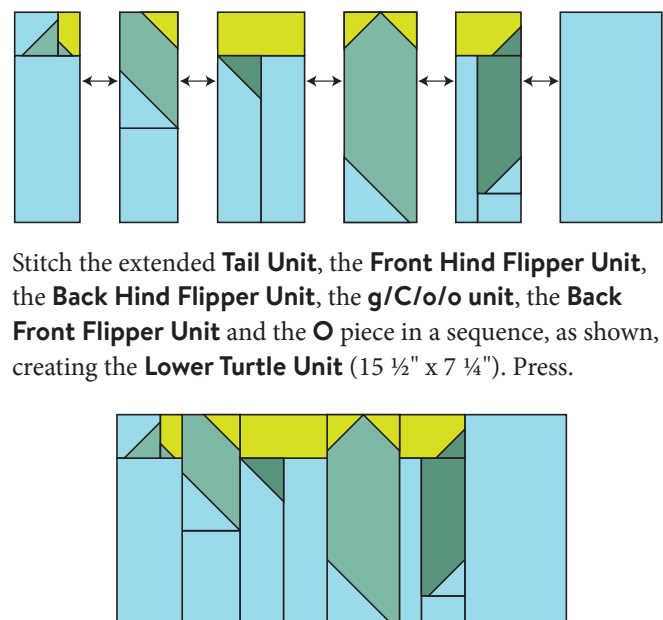

Stitch the extended **Tail Unit**, the **Front Hind Flipper Unit**, the **Back Hind Flipper Unit**, the **g/C/o/o** unit, the **Back Front Flipper Unit** and the **O** piece in a sequence, as shown, creating the **Lower Turtle Unit** (15 1/2" x 7 1/4"). Press.

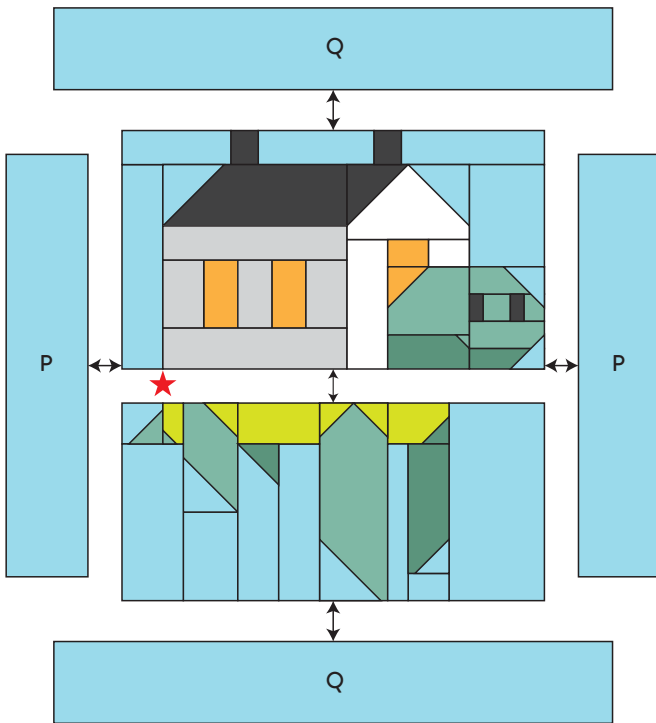

★ Stitch the **Bottom Turtle Unit** to the bottom of the **Upper Turtle Unit**, as shown, matching the point where the tail meets the house, as marked on the diagram with a star, creating the **Main Turtle Unit** (15 ½" x 15 ½"). Press.

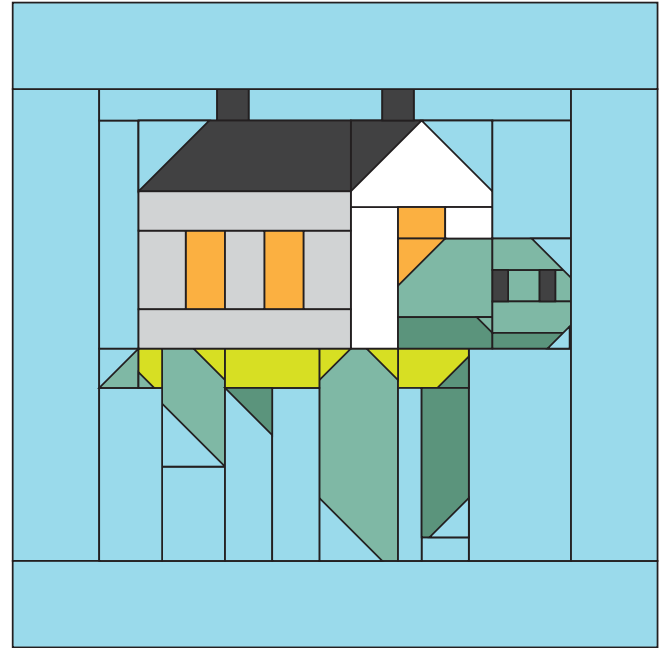

Stitch the two **P** pieces to either side of the **Main Turtle Unit**, as shown. Press. Stitch the two **Q** pieces to the top and bottom of the extended **Main Turtle Unit**, as shown. Press.

This completes the *Shell-come Home Block* (20 ½" x 20 ½"). Press. ✨

Next, you can add borders to the stand alone block for a wall hanging or other decorative use. As another option, you can make it part of a larger quilt by adding complementary blocks. Either way, feel free to share your finished design with *Canadian Quilter* by emailing photos and the story of your Shell-come Home journey to Editor Lois Tuffin: Lois.Tuffin@CanadianQuilterAdministration.com.

We are always on the lookout for pattern designers to feature in these pages. If you have a design to share, get in touch with our editor. CQA/ACC pays competitive rates for pattern designs and loves to tap into new talent.

